

BILINGUAL PAMPHLET



HYGIENIC SOLUTIONS
FOR LOAD HANDLING
IN CLEAN AREAS



SOLUCIONES HIGIENIZABLES
PARA LA MANIPULACIÓN DE CARGAS
EN SALAS BLANCAS



COMPANY BACKGROUND • ENTORNO EMPRESARIAL



ULMA Inoxtruck is currently part of the ULMA Group, one of the largest Business Groups in northern Spain with almost 50 years market experience and a clear commitment to Innovation, Employment and Value Added.

ULMA Group comprises 8 cooperative companies and It upholds a trajectory of continuous expansion and sustained growth and an approach based on human and social values. ULMA's activities embrace widely varying sectors and today there are more of 5,300 people employed in the Group, generating Total Sale greater then 900 million euros.

ULMA Inoxtruck forma parte en la actualidad del Grupo ULMA, uno de los mayores Grupos Empresariales del norte de España con casi 50 años de presencia en el mercado y un compromiso claro con la Innovación, el Empleo y el Valor Añadido.

El Grupo ULMA está formado por 8 sociedades cooperativas que abarcan sectores muy diversos con más de 5.300 personas en su seno, generando unas Ventas Totales anuales superiores a 900 millones de Euros.

OUR COMPANY • NUESTRA EMPRESA



ULMA Inoxtruck designs and manufactures material handling equipment for clean areas. We supply innovative solutions for the food industry as well as the pharmaceutical, medical, microelectronics and aeronautic clean areas.

ULMA Inoxtruck produces material handling equipment following the guidelines of hygienic designs that are required by the Good Manufacturing Practices (GMP) for the processing and packaging lines.

ULMA Inoxtruck diseña y fabrica equipos higienizables de transporte y manipulación de cargas en salas blancas de producción. Ofrece soluciones innovadoras para el sector agroalimentario y los laboratorios de industrias tan diversas como la farmacéutica, biomédica, microelectrónica o aeronáutica.

ULMA Inoxtruck ha trasladado a los equipos de manutención los conceptos del diseño higienizable tan extendidos en las Buenas Prácticas de Fabricación (GMP) de las máquinas de procesamiento o envasado del producto final.



HYGIENIC DESIGN • DISEÑO HIGIENIZABLE

HYGIENIC DESIGN

- Without lifting chains
- Without lubrication points
- Cutting edge batteries
 - Without emissions
 - Permanent charge
- 100% stainless steel
- Following ISO and GMP standards
- Electronic components with IP_{≥65} protection

EX-PROOF, Protection against explosive atmospheres

MINIMUM MAINTENANCE

QUIET

COMPACT AND DURABLE STRUCTURES

DISEÑO HIGIENIZABLE

- Sin cadenas de elevación
- Sin puntos de engrase
- Baterías de última generación
 - Sin emisiones
 - Carga permanente
- 100% inoxidable
- Siguiendo normas ISO y GMP
- Componentes electrónicos con protección IP 65

ATEX, Protección contra atmosferas explosivas

MÍNIMO MANTENIMIENTO

SILENCIOSOS

ESTRUCTURAS COMPACTAS Y DURADERAS



100% stainless steel
100% inoxidable

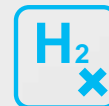

Without emissions
Sin emisiones



Open frame
Estructura abierta



Without chains
Sin cadenas



No grease fittings
Sin lubricación



Hygienic design
Diseño higienizable



Quiet
Silencioso



Minimum maintenance
Mínimo mantenimiento



Sealed bearings
Rodamientos estancos



EX-PROOF, Protection against explosive atmospheres
ATEX, Protección contra atmosferas explosivas

The Vestil Advantage:

- Founded in 1957
- Many USA manufactured products
- Fourth-generation family business
- Midwestern shipping location
- Diverse product assortment
- New product development focus
- Quick-ship program
- Custom product solutions
- Online resource center website



www.vestil.com

 800-348-0868

 ulma@vestil.com

ERGONOMY • ERGONOMIA

ERGONOMIC DESIGN

- Light and easy to handle

DISEÑO ERGONÓMICO

- Ligeroy Manejable

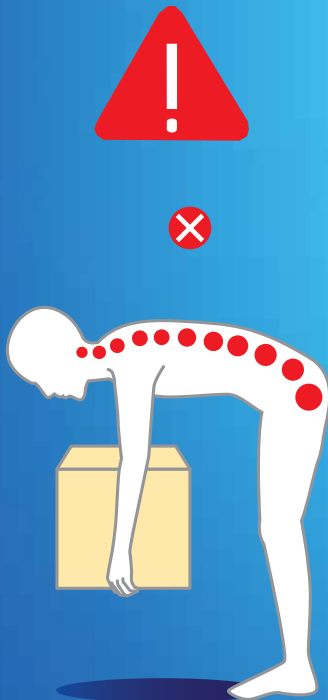

INDEX • ÍNDICE



TRANSPORT • TRANSPORTE 7 - 11



LIFTING • ELEVACIÓN 12 - 14



AUXILIARY EQUIPMENTS • EQUIPOS AUXILIARES 15 - 19



TIPPERS • VOLTEADORES 20 - 25



SPECIAL SOLUTIONS • SOLUCIONES ESPECIALES 26 - 28

TRANSPORT • TRANSPORTE

MPT15

- TRANSPALETA MANUAL
- HAND PALLET TRUCK



3300 lb



3,34-8,0 in



Code/Código	Forks/Horquilla (WxL)	L	H
MPT15XS	20 1/2	31 1/2	8
MPT15W	26 3/4	45	8
MPT15	20 1/2	45	8
MPT15XH	20 1/2	45	11 3/4
MPT15WXH	26 3/4	45	11 3/4
MPT15XL	20 1/2	53 1/5	8
MPT15WXL	26 3/4	53 1/5	8

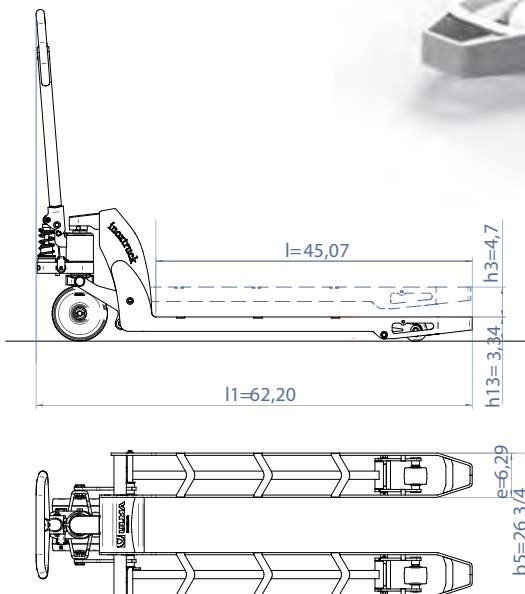

Standard



Optional



TRANSPORT • TRANSPORTE

MPT10S

- HAND PALLET TRUCK WITH SCALE
- TRANSPALETA MANUAL PESAJE



2200 lb



3,62-8,46 in



0,1%



Code/Código	Forks/Horquilla (WxL)	L	H
MPT10SW	26 3/4	48	8

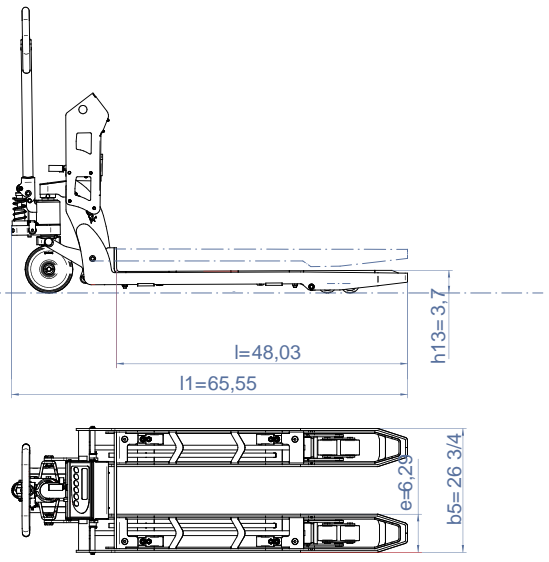

Standard

-
-
-
-
-
-
-

Optional

-
-
-



TRANSPORT • TRANSPORTE

EXT10

- ELECTRIC SCISSOR
- TRANSPALETA TIJERA



2200 lb



31,50 in



Code/Código	Forks/Horquilla (WxL)	L	H
EXT10W	26 3/4	47 1/4	31 1/2
EXT10	21 1/4	47 1/4	31 1/2
EXT10XH	21 1/4	47 1/4	39 3/8
EXT10WXH	26 3/4	47 1/4	39 3/8

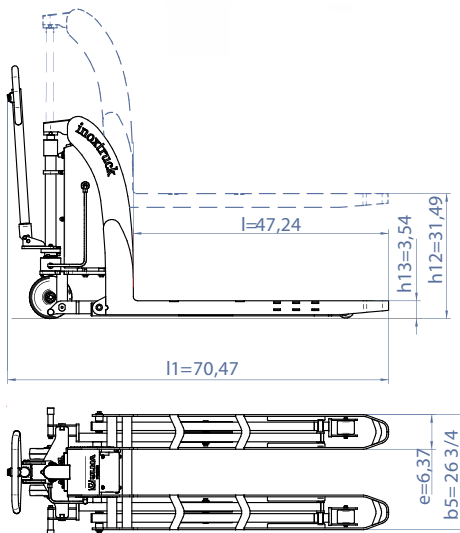

Standard



Optional



TRANSPORT • TRANSPORTE

EPT

• ELECTRONIC WALKIE PALLET TRUCK
• TRANSPALETA ELECTRÓNICA ACOMPAÑANTE



3500 lb
4400 lb
5500 lb



3,50-8,25 in



304
stainless
steel



Code/Código	Forks/Horquilla (WxL)	L	H
EPTxxS	21 1/4	41 1/3	8 1/4
EPTxx	21 1/4	44 1/2	8 1/4
EPTxxW	26 3/4	44 1/2	8 1/4
EPTxxL	21 1/4	53 1/5	8 1/4
EPTxxXL	21 1/4	57	8 1/4
EPTxxDUO	21 1/4	92 1/2	8 1/4
EPTxxXH	21 1/4	44 1/2	12 1/2
EPTxxERGO	21 1/4	44 1/2	31 1/2

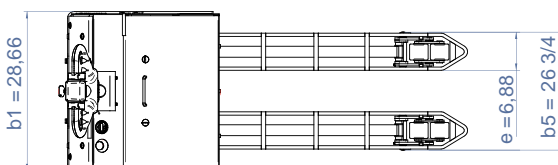
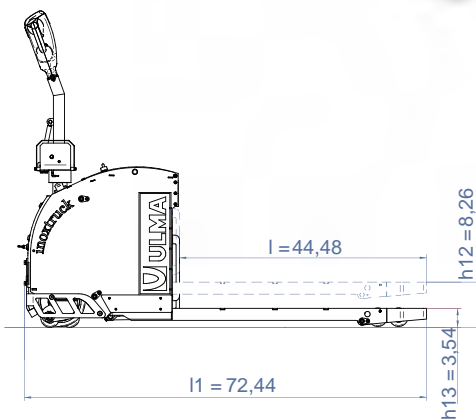

Standard



Optional



TRANSPORT • TRANSPORTE

PPT

- ELECTRONIC PLATFORM PALLET TRUCK
- TRANSPALETA ELECTRÓNICA PLATAFORMA



4400 -5500 lb



3,50-8,25 in

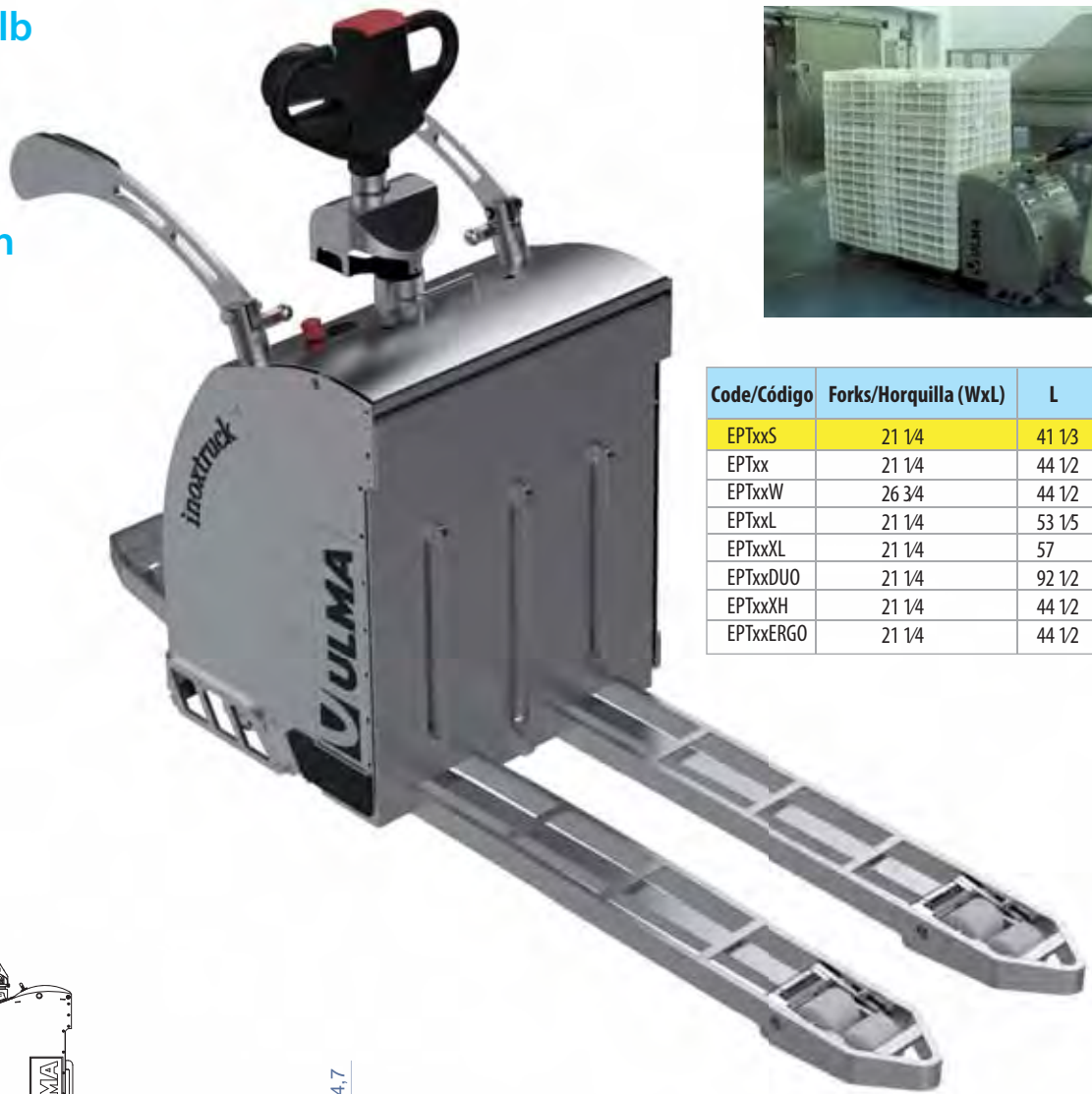

Code/Código	Forks/Horquilla (WxL)	L	H
EPTxxS	21 1/4	41 1/3	8 1/4
EPTxx	21 1/4	44 1/2	8 1/4
EPTxxW	26 3/4	44 1/2	8 1/4
EPTxxL	21 1/4	53 1/5	8 1/4
EPTxxXL	21 1/4	57	8 1/4
EPTxxDUO	21 1/4	92 1/2	8 1/4
EPTxxXH	21 1/4	44 1/2	12 1/2
EPTxxERGO	21 1/4	44 1/2	31 1/2

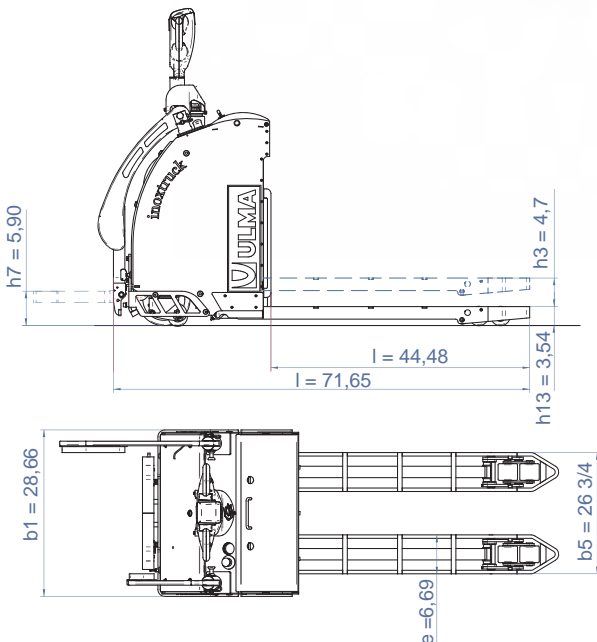

Standard



Optional



LIFTING • ELEVACIÓN

EPS

- ELECTRONIC WALKIE STACKER DOUBLE TRACTION
- APILADOR ELECTRÓNICO DOBLE TRACCIÓN



2200-3300 lb



Up to 13 ft



Code/Código	Forks/Horquilla (WxL)	L	H2 (in)	H3 (in)
EPSxxS15	22	47 1/4	59	59
EPSxxD26	22	47 1/4	6	102
EPSxxD32	22	47 1/4	51	102
EPSxxT34	22	47 1/4	52 3/4	133 3/4
EPSxxT42	22	47 1/4	57 3/4	165 1/4



Elevación inicial
Initial lift

4,92 in

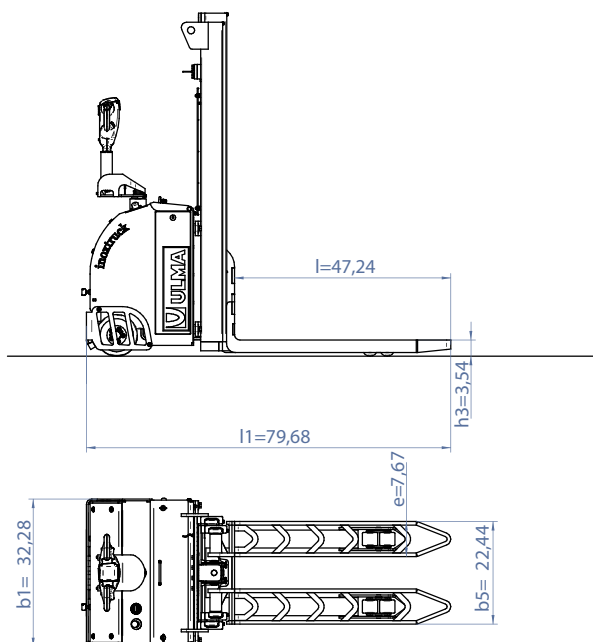

Standard



Optional



LIFTING • ELEVACIÓN

**EPS10
MRM**

- ELECTRONIC WALKIE STACKER SINGLE TRACTION
- APILADOR ELECTRÓNICO MONORUEDA



2200 lb



Up to 10 ft

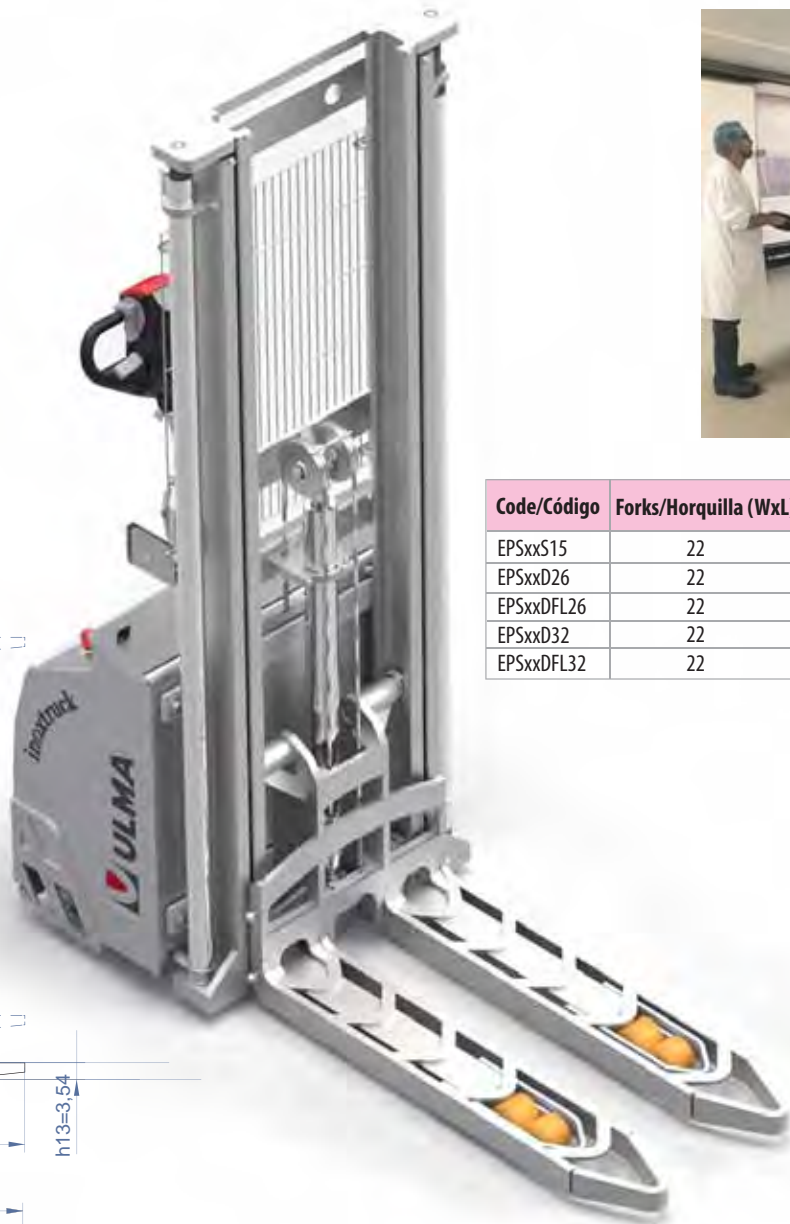

Code/Código	Forks/Horquilla (WxL)	L	H2 (in)	H3 (in)
EPSxxS15	22	47 1/4	59	59
EPSxxD26	22	47 1/4	6	102
EPSxxDFL26	22	47 1/4	51	102
EPSxxD32	22	47 1/4	6	126
EPSxxDFL32	22	47 1/4	63	126

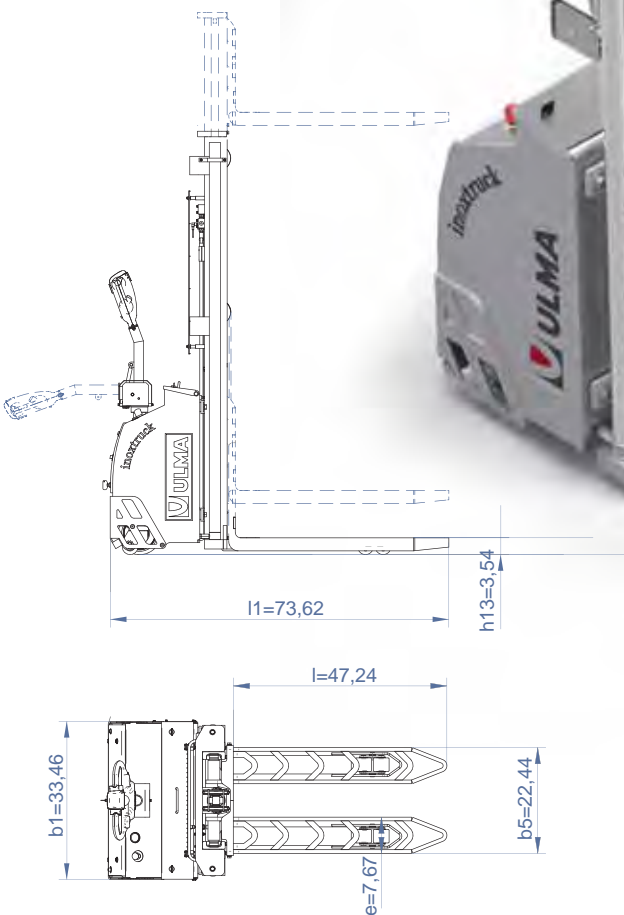

Standard



Optional



LIFTING • ELEVACIÓN



- ELECTROMANUAL STACKER
- APILADOR ELECTROMANUAL



440-2200 lb



110,25 in

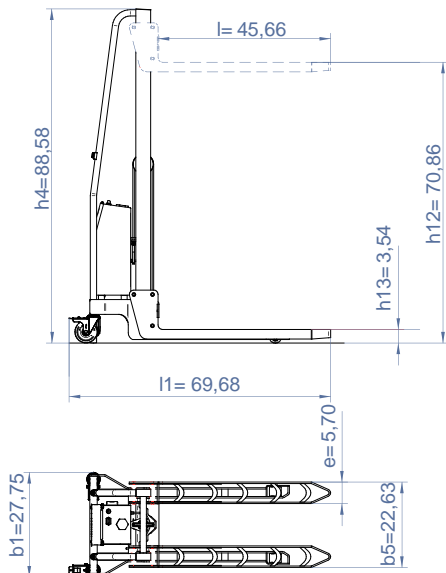

Code/Código	Forks/Horquilla (WxL)	L	H3
EMSxxS15	22 1/2	45 1/2	59
EMSxxS18	22 1/2	45 1/2	70 3/4
EMSxxS20	22 1/2	45 1/2	80 1/2
EMSxxD28	22 1/2	45 1/2	110

Standard



Optional



- MANUAL LOAD STACKER
- APILADOR MANUAL



1300 lb



78,74 in



Standard



Optional



AUXILIARY EQUIPMENTS • EQUIPOS AUXILIARES

MS/EMS

- MANUAL/ELECTROMANUAL ROLL HANDLER
- APILADOR PORTABOBINAS MANUAL/ELECTROMANUAL



220-440 lb



61 in

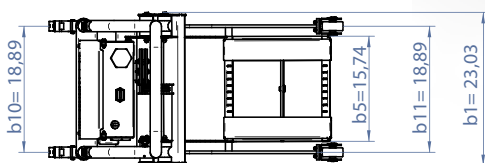
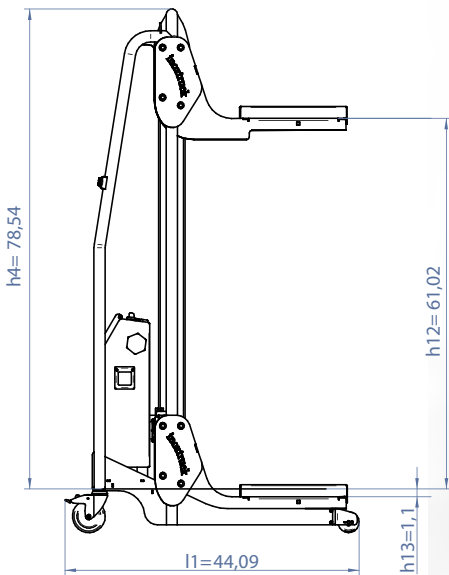

Standard



Optional



•OPTIONS
•OPCIONES



- Collar change
- Cambio de corbatas
- Reglades multiples
- Bandwechsel



- Rolls rotator 90°, max. 100 kgs
- Rotador bobinas 90°, max. 100 kgs
- Retourneur de bobines par mandrin, max. 100 kg
- 90° Rollendrehvorrichtung, max. 100 kgs



- Up to 200 kgs. with manual clamping and rotation.
- Apriete y giro manual. Elevación eléctrica. Hasta 200 kg.
- Levée électrique. Serrage et retournement latéral avec volants manuels. Capacité de lavage jusqu'à 200 kg.
- Manuelles Drehen und Klammern von Rollen bis 200 Kg.
- Heben : Elektrisch. Fahren: Manuell.

AUXILIARY EQUIPMENTS • EQUIPOS AUXILIARES

MRS400

- BOTTOM ROLL TROLLEY
- CARRO PORTABOBINAS



880 lb



17,71 in



Code/Código	Roll/Bobina	L	H3
MRS400	19 1/2	27 1/2	17 1/2
MRS400XL	27 1/2	39 1/4	17 1/2
MRS400XH	19 1/2	27 1/2	22

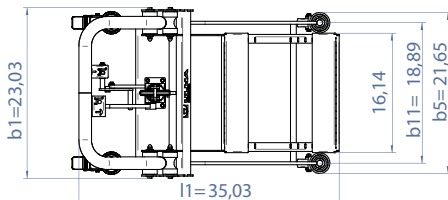
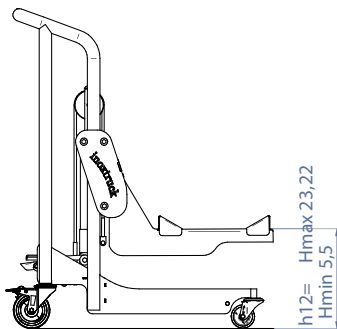

- Long roll handled on the mandrel.
- Bobina ancha manipulación por el mandrino.
- Manipulateur de bobines à laize extra-large.
- Aufnahme von Rollen über die Laufachse.

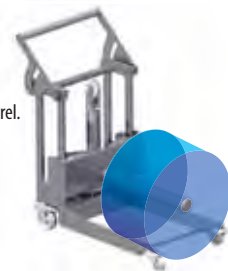

- Trolley with spike.
- MRS con pincho y asa abatible.
- Option poignée rabattable sur le chariot porte bobine.
- Fahrwagen mit Dorn.

Standard



Optional



- Ground taxi for JUMBO rolls.
- Transporte de bobinas diámetro de 1.000 mm.
- Option maution des bobines jusqu'à 1000 x 1000 mm.
- Transportwagen für Rollen mit großem Durchmesser



- Side adjustable stoppers for thin rolls.
- Bobina estrecha.
- Manipulateur de bobines à laize étroite.
- Justierbare seitliche Arme.

AUXILIARY EQUIPMENTS • EQUIPOS AUXILIARES

EMSxxTD

- DRUM/ROLL ROTATOR
- ROTADOR BIDONES/BOBINAS



660 lb



59 in

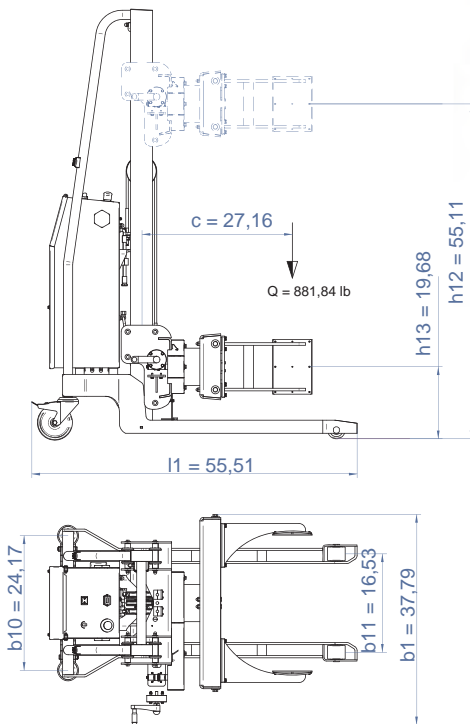

Standard



Optional



1250 lb



AUXILIARY EQUIPMENTS • EQUIPOS AUXILIARES

EMS300TE

- EUROBIN ROTATOR/STACKER
- APILADOR/ROTADOR EUROBINOS



660 lb



39,37 in

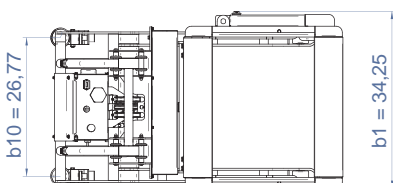
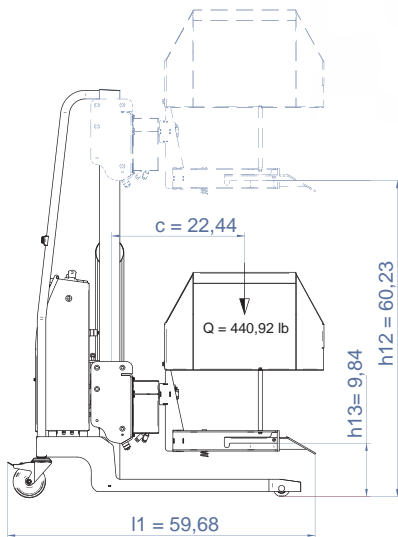
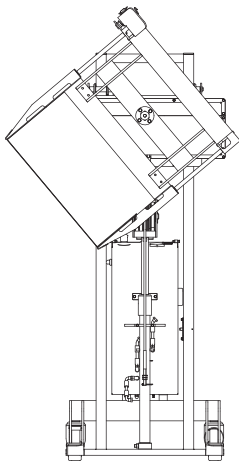

Standard



Optional



1250 lb



TIPPERS • VOLTEADORES

EBT750

- BOX-TUBS TILTER
- INCLINADOR CONTENEDOR



1650 lb



29,50 in



<90°

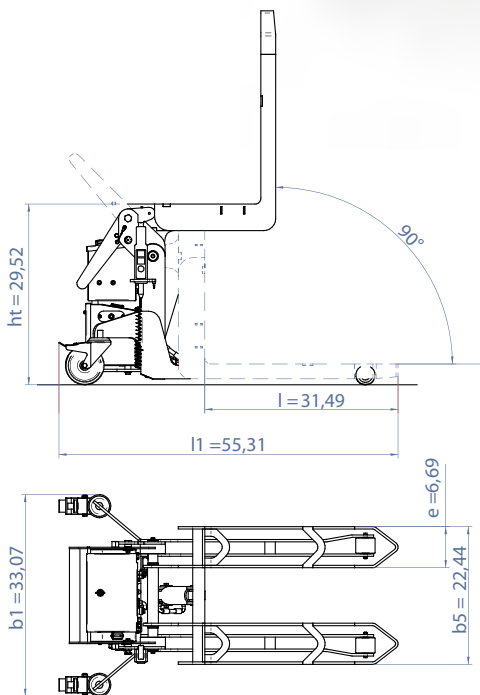

1653,47 lb

Standard



Optional



35,40 in



TIPPERS • VOLTEADORES

EBT750i

- BOX-TUBS TILTER
- INCLINADOR CONTENEDOR



1650 lb



29,50-37,40 in



<90°



304
stainless steel

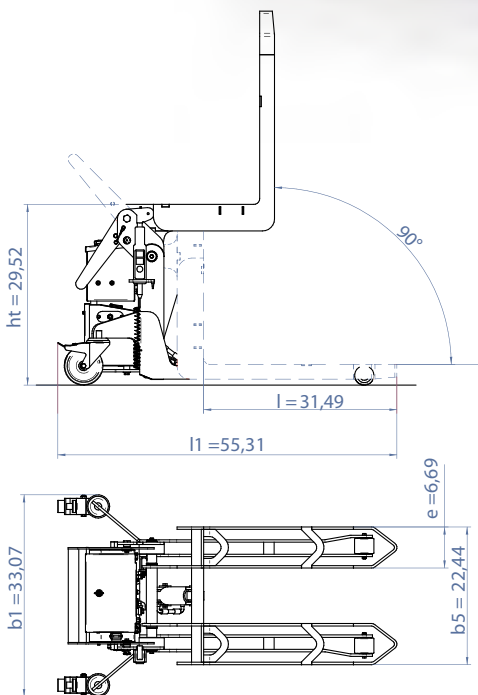

1653,47 lb



Standard

-
-
- 100% stainless steel
-
-
- GEL

Optional

- 316 stainless steel
- Li-ion
- 110v
- ATEX



TIPPERS • VOLTEADORES

EBT300

- EUROBINS/DRUMS TIPPER
- VOLTEADOR EUROBINS/BIDONES



EBT300E



660 lb



<130°



51 in

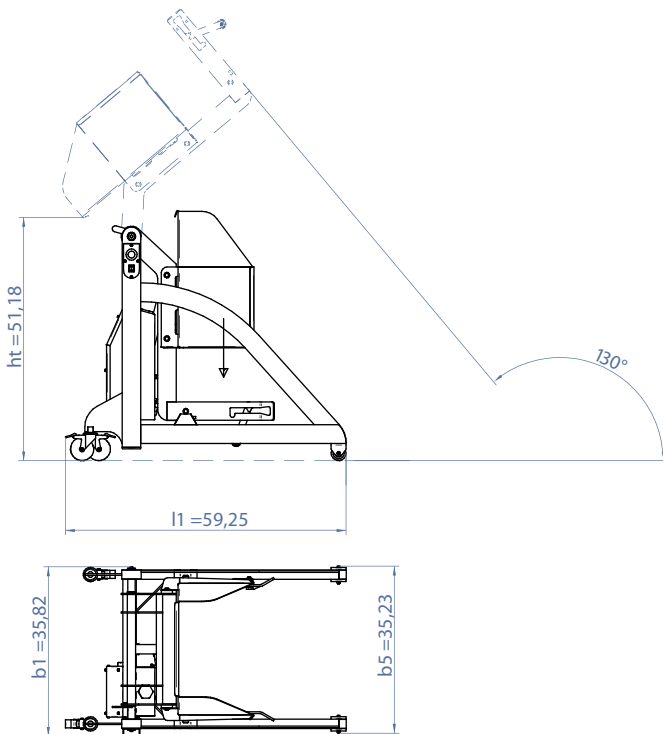

EBT300D



Standard



Optional



TIPPERS • VOLTEADORES

EBT10

- TUBS TIPPER
- VOLTEADOR CONTENEDORES



2200 lb



39,30-51 in



<115°



304
stainless steel

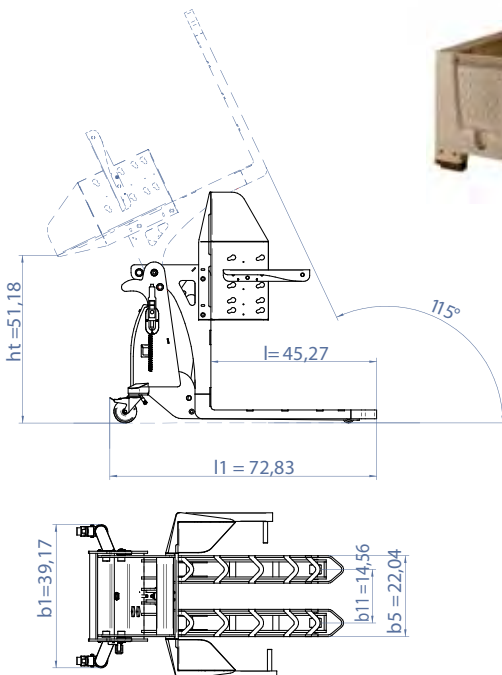
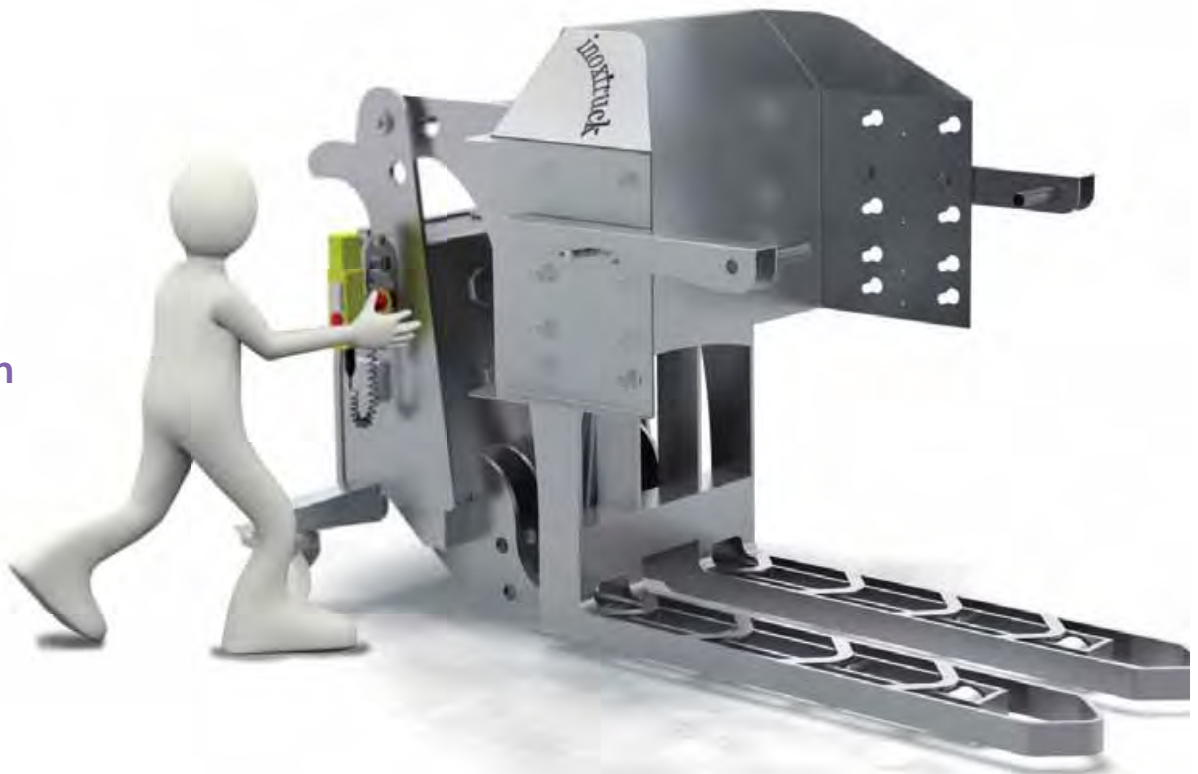

Standard



Optional



TIPPERS • VOLTEADORES

EBT10i

- TUBS TIPPER INITIAL FORK LIFT
- VOLTEADOR CONTENEDORES ELEVACIÓN INICIAL



2200 lb



51,10-59 in



<115°



304
stainless steel



7,87 p

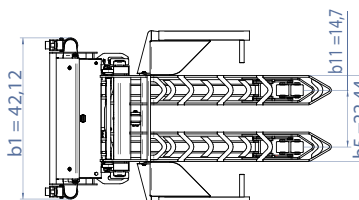
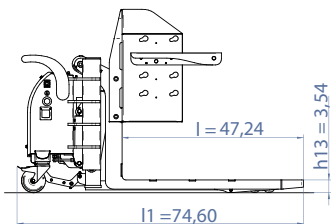
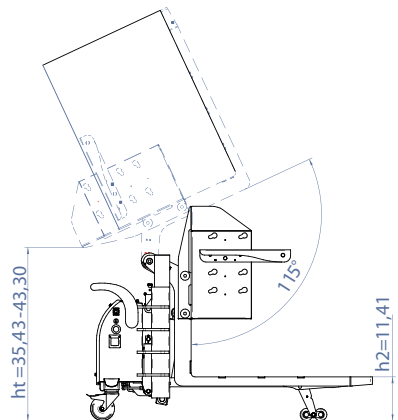

Standard



Optional



TIPPERS • VOLTEADORES

EBT10S

- TUBS TIPPER
- VOLTEADOR CONTENEDORES



2200 lb



51-59 in



<115°



EBT10S2E

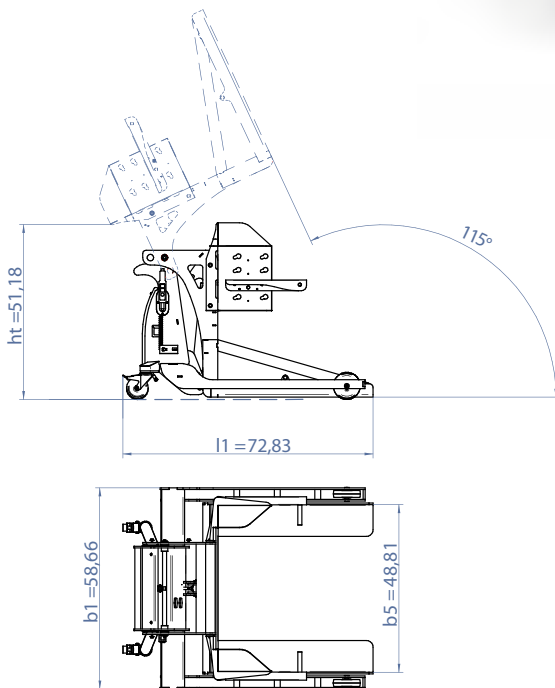

Standard



Optional



SPECIAL SOLUTIONS • SOLUCIONES ESPECIALES



- Roll guided stackers
- Apiladores guiados



- Big Tank 4800 lb handling
- Apilador de 4800 lb para depósito inoxidable



- Automated Guided Vehicles (AGV)
- Chariots automatiques



- Drum front tilting attachment
- Accesorio frontal torna-bidones



- IBC Rotator
- Rotador de IBCs

SPECIAL SOLUTIONS • SOLUCIONES ESPECIALES



- Drum ring handling
- Porta bidón picoloro



- Basin pneumatic stacker
- Elevador neumático de bañeras



- Cage clamping device
- Sistema de sujeción de jaulas

OUR CUSTOMERS • NUESTROS CLIENTES



COMMERCIAL NETWORK • RED DE DISTRIBUCIÓN

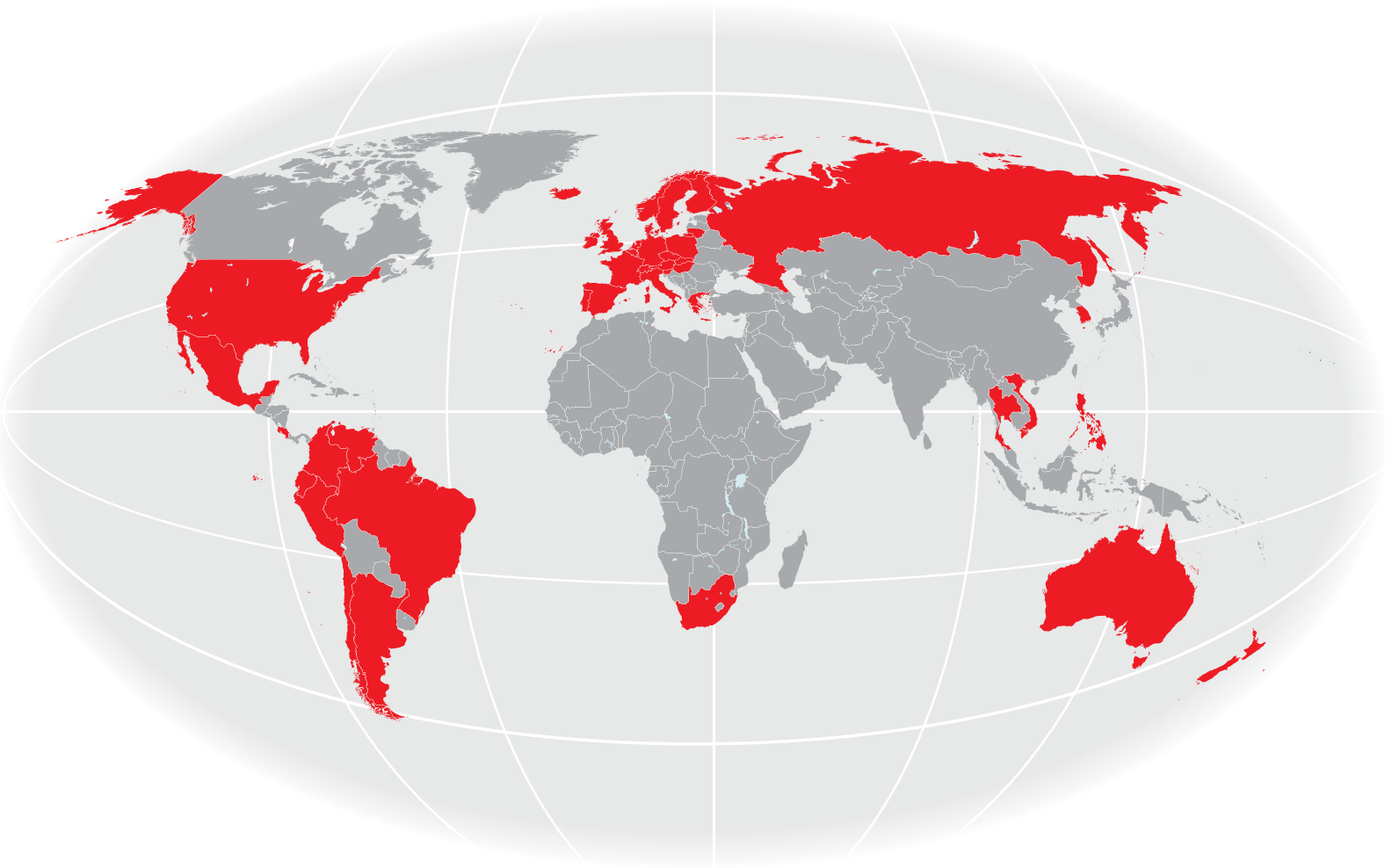

Inoxtruck



Paseo Otadui, 10
20560 OÑATI (Gipuzkoa) SPAIN
Te: +34 943 848 943
info@ulmainoxtruck.com
www.ulmainoxtruck.com



Distributed by/Distribuido por:

